

In situ measurements of Reflection Index and Sound Insulation Index of noise barriers

Lamberto Tronchin (1), Andrea Venturi (1), Angelo Farina (2) and Christian Varani (2)

(1) DIENCA - CIARM - University of Bologna, Viale Risorgimento, 2, 40136 Bologna, Italy
 (2) Industrial Engineering Dept., University of Parma, Via G.P. Usberti 181/A, 43124 Parma, Italy

PACS: 43.50.Gf, 43.58.Gn, 43.55.Rg, 43.55.Ev

ABSTRACT

Barriers employed for road traffic noise reduction can be characterized by two indices: reflection index for sound reflection and insulation index for airborne sound insulation. They can be measured following the method described in CEN/TS 1793-5 standard, based on impulse response measurements employing a pressure microphone. The method mandates for averaging results of measurements taken in different points in front of the device under test and/or for specific angles of incidence, employing the obsolete MLS signal for performing the measurements, which can cause severe artefacts due to nonlinearity and time-variance of the system. Furthermore, the CEN/TS 1793-5 standard presents some geometric problems, which could arise if the barrier does not reach a minimum height or if it has a very rough (scattering) surface. During the reflection index measurement on a barrier of limited height, the reflected sound can be contaminated by the ground reflection, compromising the fairness of the whole result. Also the insulation index can be affected by the height of the noise barrier, since the sound passing above the device under test can become mixed with the sound passing through it. It has been noticed how these practical problems, jointly with the assumption of a surface reflecting specularly in the final formula, can significantly over/under estimate the laboratory values of both the indices. Results of in situ tests based on CEN/TS 1793-5 will be shown in comparison with results obtained through a different approach, based on sound intensity measurements, and with the traditional tests performed in the lab.

CEN/TS 1793-5 STANDARD

Brief summary

CEN/TS 1793-5 standard describes a way to calculate two indices, reflection index and sound insulation index, used to characterize barriers employed for road traffic noise reduction. For both the indices the method mandates for averaging results of measurements taken in different points in front of the device under test (sound insulation index) and/or for specific angles of incidence (reflection index). These indices are computed in one-third octave frequency bands; they describe how much the device under test reflects a sound wave back towards the source and how much the device under test attenuates a sound wave passing through (not above) the barrier.

Reflection index

Equation (1) shows how to obtain the reflection index RI for every one-third octave frequency band under test:

$$RI_j = \frac{1}{n_j} \cdot \frac{\sum_{k=1}^{n_j} \int_{\Delta f_j} |F[t \cdot h_{r,k}(t) \cdot w_r(t)]|^2 \cdot df}{\int_{\Delta f_j} |F[t \cdot h_i(t) \cdot w_i(t)]|^2 \cdot df} \quad (1)$$

where:

- j is the index of the one-third octave frequency bands (100 Hz to 5 kHz);
- n_j is the number of angles to average, which is frequency-dependent, as shown in Table 1;
- Δf_j is the width of the j -th one-third octave frequency band;
- F is the symbol of the Fourier transform;
- t is the time counted since the instant when the pulse was emitted by the sound source;
- $h_{r,k}(t)$ is the reflected component of the impulse response at the k -th angle;
- $w_r(t)$ is the time window applied to the reflected component (Adrienne window, Figure 1);
- $h_i(t)$ is the incident reference component of the free-field impulse response;
- $w_i(t)$ is the time window applied to the incident reference free-field component (Adrienne window).

Once the reflection index for all the bands has been calculated, it is possible to obtain a single value in dB(A), to characterize the road traffic noise reduction barrier in its totality:

$$DL_{RI} = -10 \cdot \log_{10} \left[\frac{\sum_{i=m}^{18} (RI_i \cdot 10^{0.1 \cdot L_i})}{\sum_{i=m}^{18} (10^{0.1 \cdot L_i})} \right] \quad (2)$$

where:

$m = 4$ (number of the 200 Hz one-third octave frequency band);

L_i Relative A-weighted sound pressure levels (dB) of the normalized traffic noise spectrum, as defined in EN 1793-3, in the i -th one-third octave band.

Before using (1) and then (2) it is necessary to measure $h_i(t)$ and all the $h_{r,k}(t)$. CEN/TS 1793-5 standard suggests employing a measurement equipment as sketched in Figure 2. The equipment is composed of a single-way loudspeaker, a pressure microphone attached to the loudspeaker's case and a stand to hold them up. The stand shall rotate both in the vertical plane and in the horizontal plane (it depends on the barrier's height and width features) and shall be as high as half the barrier.

ponent, so it can be cancelled by subtraction of the two waveforms.

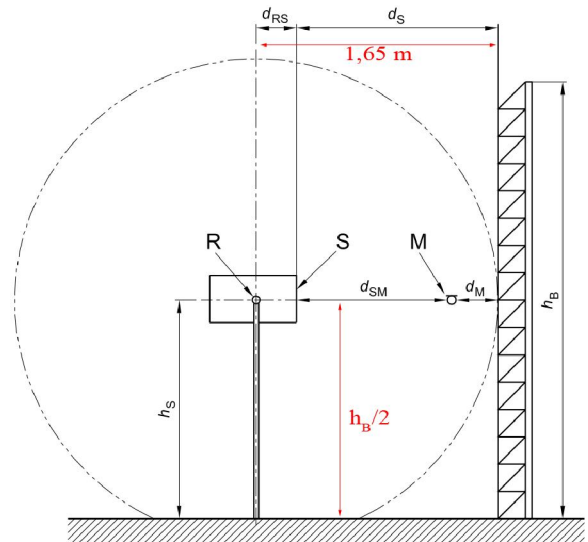

Figure 2. – Sound Reflection geometrical layout according to CEN/TS 1793/5

Table 1. Frequency Band - angle relationship

f (Hz)	50°	60°	70°	80°	90°	100°	110°	120°	130°
100					X				
125					X				
160					X				
200					X				
250				X	X	X			
315		X	X	X	X	X	X	X	
400		X	X	X	X	X	X	X	
500	X	X	X	X	X	X	X	X	X
630	X	X	X	X	X	X	X	X	X
800	X	X	X	X	X	X	X	X	X
1000	X	X	X	X	X	X	X	X	X
1250	X	X	X	X	X	X	X	X	X
1600	X	X	X	X	X	X	X	X	X
2000	X	X	X	X	X	X	X	X	X
2500	X	X	X	X	X	X	X	X	X
3150	X	X	X	X	X	X	X	X	X
4000	X	X	X	X	X	X	X	X	X
5000	X	X	X	X	X	X	X	X	X

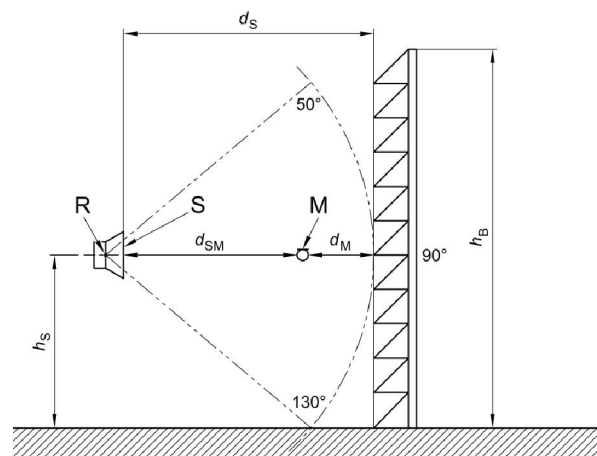

Figure 3. Vertical rotation of the measurement equipment according to CEN/TS 1793/5

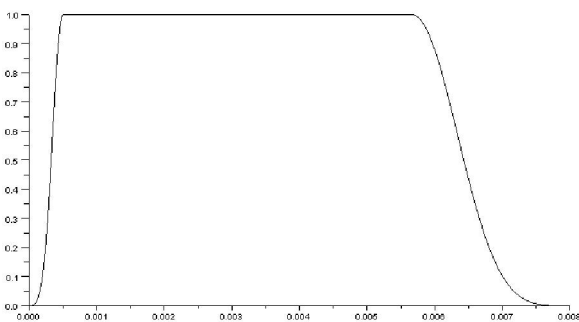

Figure 1. Adrienne window

As said before $h_i(t)$ is the incident impulse response in free-field condition. It is obtained by measuring the impulse response of the system when it doesn't point to the barrier, e.g. it faces the sky. $h_{r,k}(t)$ is the reflection component of the impulse response when the measurement equipment points the barrier with the k -th incidence angle. $h_{r,k}(t)$ is obtained subtracting the free-field impulse response from the measured k -th angle impulse response, which contains information about the direct and the reflected path: as the microphone is bonded to loudspeaker's case both the free-field and the k -th angle impulse response will contain the same incident com-

The CEN/TS 1793-5 standard suggests to measure the impulse responses employing the Maximum Length Sequence (MLS) signal, although the Exponential Sine Sweep (ESS) signal could have been a better choice, thanks to its immunity to system's nonlinearities and time-variance [1,2,3,4].

It is well known how system's nonlinearities cause the appearance of spurious peaks in the impulse responses measured with the MLS method. Furthermore, time variance can significantly reduce the high-frequency contents of the measured impulse response, if synchronous averaging is employed [5] (as it is common, and recommended in the standard, for improving the Signal-to-Noise ratio when working with MLS).

Generally speaking, MLS is a method only suitable for laboratory measurements under controlled conditions, it should never be employed outdoors, for in-situ measurements.

However, a careful usage of the MLS signal makes it possible to get impulse responses which are reasonably artefact-free, at least for the segments inside the time windows required for the processing. And the CEN/TS 1793-5 standard allows for usage of methods different from MLS, so in this work the ESS method was preferred.

$w_i(t)$ and $w_r(t)$ represent an analytically-defined window (Adrienne window) that has to be applied respectively to $h_i(t)$ and $h_{r,k}(t)$. CEN/TS 1793-5 standard provides a well documented way to do that.

The running time t is used to compensate for the linear attenuation of the amplitude due to the increasing travel path. Its origin is at the beginning of the impulse response acquired by the measurement chain: if d_{sm} represents the distance between the front panel of the loudspeaker and the microphone and c is the speed of sound, the zero-value of t is located d_{sm}/c seconds before the first peak of the impulse response.

Sound insulation index

Equation (3) shows how to obtain the sound insulation index SI for every one-third octave frequency band.

$$SI_j = -10 \cdot \log_{10} \left\{ \frac{\sum_{k=1}^n \left(\frac{d_k}{d_i} \right)^2 \cdot \int_{\Delta f_j} |F[h_{t,k}(t) \cdot w_{t,k}(t)]|^2 \cdot df}{n \cdot \int_{\Delta f_j} |F[h_i(t) \cdot w_i(t)]|^2 \cdot df} \right\} \quad (3)$$

where:

- n 9, is the number of scanning points;
- Δf_j is the width of the j -th one-third octave frequency band (between 100 Hz and 5 kHz);
- F is the symbol for the Fourier transform;
- $h_{t,k}(t)$ is the transmitted component of the impulse response at the k -th scanning point;
- $w_{t,k}(t)$ is the time window applied to the transmitted component (Adrienne window, Figure 1);
- d_k is the geometrical spreading correction factor for the transmitted component at the k -th scanning point (Table 2);
- d_i is the geometrical spreading correction factor for the reference free-field component (Table 2);
- $h_i(t)$ is the incident reference component of the free-field impulse response;
- $w_i(t)$ is the time window applied to the incident reference free-field component (Adrienne window).

Table 2.

d_1	$\sqrt{d_i^2 + 2 \cdot s^2}$
d_2	$\sqrt{d_i^2 + s^2}$
d_3	$\sqrt{d_i^2 + 2 \cdot s^2}$
d_4	$\sqrt{d_i^2 + s^2}$
d_5	$1.25 + t_b$

d_6	$\sqrt{d_i^2 + s^2}$
d_7	$1.25 + t_b$
d_8	$\sqrt{d_i^2 + s^2}$
d_9	$\sqrt{d_i^2 + 2 \cdot s^2}$
d_i	$1.25 + t_b$
s	0.40 m
t_b	Barrier thickness (m)

Once the sound insulation index for all the bands has been calculated, it is possible to obtain a single value, in dB(A), to characterize the road traffic noise reduction barrier in its totality:

$$DL_{SI} = -10 \cdot \log_{10} \left[\frac{\sum_{i=m}^{18} [10^{0.1 \cdot (L_i - SI_i)}]}{\sum_{i=m}^{18} (10^{0.1 \cdot L_i})} \right] \quad (4)$$

where:

- m = 4 (number of the 200 Hz one-third octave frequency band);
- L_i Relative A-weighted sound pressure levels (dB) of the normalized traffic noise spectrum, as defined in EN 1793-3, in the i -th one-third octave band.

Before using (3) and then (4) it is necessary to calculate $h_i(t)$ and all the $h_{t,k}(t)$. CEN/TS 1793-5 standard suggests employing a measurement system sketched in Figure 4 and Figure 5. The equipment is composed of a loudspeaker and its own stand, a panel with 9 predefined positions in which a pressure microphone will be hosted and a stand for it, Figure 5. Both the stands need to be as high as the half of the barrier.

Figure 6 shows how to position the equipment for the reference $h_i(t)$ measurement: the loudspeaker is perfectly in line with the microphone, placed in the 5-th position of the panel of Figure 5, at a well defined distance d_i . MLS signal (or Sine Sweep) can be employed to obtain the impulse response.

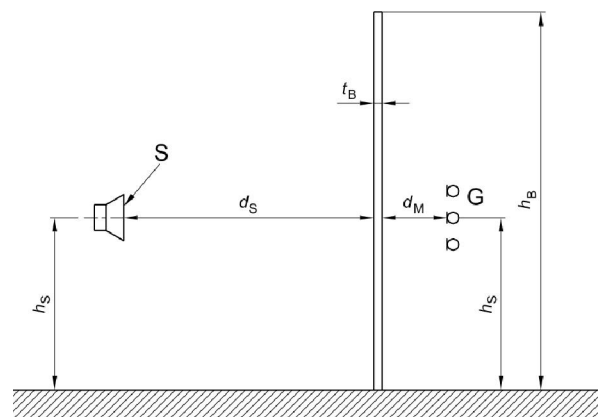

Figure 4 – Sound Insulation geometrical layout according to CEN/TS 1793/5

$w_i(t)$ and $w_{i,k}(t)$ represent an analytically-defined window (Adrienne window) that has to be applied respectively to $h_i(t)$ and $h_{i,k}(t)$. CEN/TS 1793-5 standard provides a well documented way to do that.

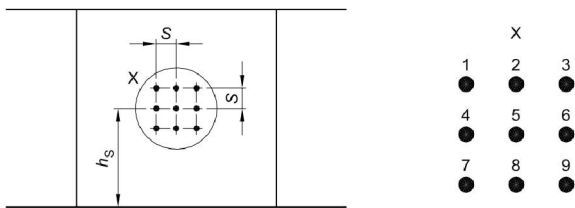

Figure 5 – Sound Insulation geometrical layout according to CEN/TS 1793/5

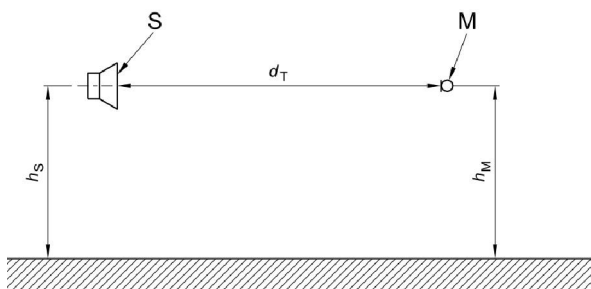

Figure 6 – Reference measurement according to CEN/TS 1793/5

It is necessary to replicate the whole SI procedure both in front of the element and in front of the post (if present). Whenever possible two single-number rating shall be derived to indicate the performance of the product: one for elements and the other for posts.

PRACTICAL PROBLEMS

Minimum height for RI Index

CEN/TS 1793-5 places some constraints which should be met to properly employ the described measurement method for RI index measurements: width and height of the barrier, in particular, should reach minimum values.

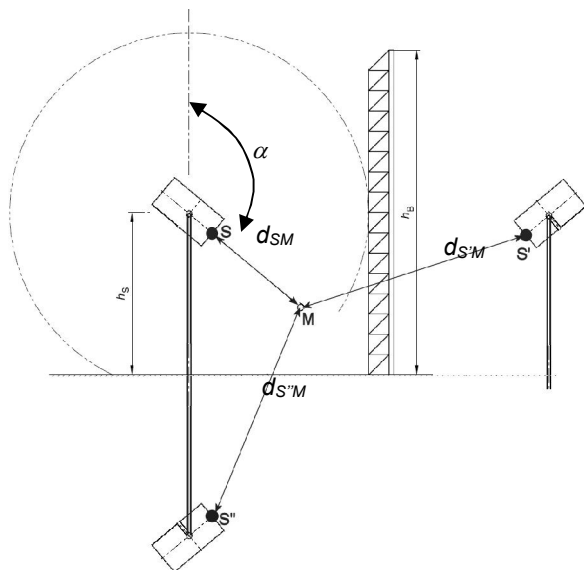

Figure 7 – Mirror images sources

Figure 7 shows how to define the minimum theoretical barrier height which maintains enough delay for the sound wave reflected from the ground, avoiding that its time-of-arrival becomes too close to the time-of-arrival of the sound reflected from the barrier.

As shown in fig. 7, when the microphone is maximally angled towards the ground (with an aiming angle of 40 degrees below horizontal, that is, $\alpha = 130^\circ$), it receives three wave-fronts: the direct sound from the loudspeaker (source S), the reflected sound from the barrier (image source S') and the reflected sound from the ground (image source S''). By simple trigonometric calculations we get the three time-of-arrivals:

$$t_o = \frac{d_{SM}}{c}$$

$$t_b = \frac{d_{S'M}}{c} = \frac{\sqrt{[d_{SM} \cdot \cos(\alpha)]^2 + [2 \cdot (d_{SM} + d_M) - d_{SM} \cdot \sin(\alpha)]^2}}{c}$$

$$t_g = \frac{d_{S''M}}{c} = \frac{\sqrt{[d_{SM} \cdot \sin(\alpha)]^2 + [h_b + d_{SM} \cdot \cos(\alpha)]^2}}{c}$$

(5)

Please note that these formulas provide a realistic estimate of the time-of-flight of the three signals. Indeed, these formulas do NOT correspond to the indication found at point 4.4.6 of the CEN/TS 1793-5 standard, which instead suggest as the time-of-flight for the sound reflected from the barrier, the following expression:

$$t_b = \frac{d_{S'M}}{c} = \frac{d_{SM} + 2 \cdot d \cdot M}{c}$$

(6)

which is correct just for $\alpha = 90^\circ$. If now we assume that:

$$d_{SM} = 1.25\text{m} ; d_M = 0.25\text{m} ; \alpha = 130^\circ$$

we can find the minimum height of the barrier for which the delay between the sound reflected from the ground and the sound reflected from the barrier is equal or greater than 7.2 ms (the remaining length of the Adrienne window located after the nominal point of arrival of the sound reflected from the barrier) :

$$h_b \geq 5.35 \text{ m}$$

(7)

A simple geometrical construction shows that the ground reflection always arrives before the sound diffracted by the upper free edge of the screen, and thus, if the condition (7) is met, the measurement is correct at every angle.

CEN/TS 1793-5 mandates for a minimum width and height of 4 meters for the acoustic element, which is clearly not enough for ensuring to get impulse responses not contaminated from the ground reflection. The standard recommends to employ horizontal rotation, instead of vertical rotation, for samples having limited height and conspicuous wideness and distance between posts. However it is common to find barriers having height smaller than 5.35m, and with distance between posts even smaller (typically 3.00 m), as shown in fig. 9: in these cases it is not possible to avoid contamination by the ground reflection if the vertical rotation is chosen, but it isn't either possible to avoid contamination from post's reflection if the horizontal rotation is chosen.

Due to these limitations, in most cases the CEN/TS 1793-5 is not applicable: but the standard does not explicitly declare these geometrical constraints, and it does not suggest an alternative measurement method when these constraints are not verified. Of consequence, wrong test reports can be obtained

following the letter of the standard, with reference to the Sound Reflection Index.

Minimum height for SI Index

In Sound Insulation Index, width and height of the barrier are again the limiting factors. In the Sound Insulation Index formula (3), we see the component of the impulse response transmitted through the barrier in its numerator.

By properly placing the Adrienne window, in principle it should be possible to insulate that component. An impulse response, measured by the pressure microphone on the right stand, is composed by a direct component, a transmitted component, a diffracted component and by parasitic reflection; however, as it can be seen in Figure 8, separating these components can be difficult.

As both stands need to be placed at half the height of the barrier, if the barrier's height is too small, the diffracted component has not enough delay for the transmitted component to extinguish, before the arrival of the diffracted one.

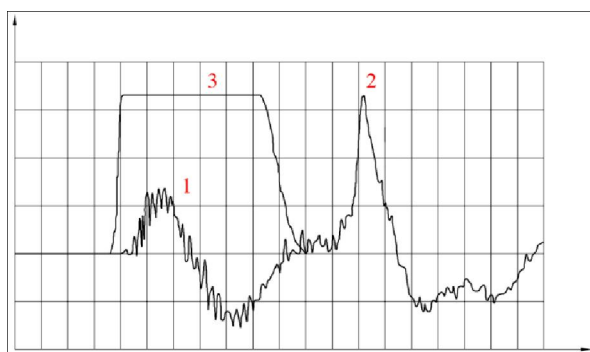

Figure 8.

Sketch of an impulse response during SI measurements.
Source: (CEN/TS 1793-5 standard, January 2006)

Figure 8 shows a sketch of an impulse response of a SI measurements. 1 represents the transmitted component, 2 the diffracted component, 3 is the Adrienne window needed to isolate 1. The delay of the component 2 (diffracted component) is related with the height of the barrier. Of course, the distance between component 1 and 2 decreases when the barrier become smaller (2 moves left). The amplitude of 2 behaves oppositely: decreasing the barrier height causes an increase in the amplitude. This behavior generates two troublesome scenarios:

- The height of the barrier provides components partially overlapping, with the diffracted component having an amplitude higher than the transmitted one: the operator could cut away completely the diffracted component by shortening the Adrienne window, thus removing also the “tail” of the transmitted one which is overlapped with the subsequent diffracted component. This results in an overestimation of the Sound Insulation Index, as part of the sound passing through the barrier has been cut away.
- The operator maintains a standard length of the Adrienne window, which will include also the strong peak of the diffracted sound, which will be improperly considered as being part of the transmitted component. This results in an underestimation of the Sound Insulation Index, as part of the sound diffracted by the upper edge of the barrier

has been erroneously included in the transmitted component.

The CEN/TS 1793-5 standard mandates for a minimum height of the barrier equal to 4.0m. Our experience demonstrated that this minimum height can be insufficient for avoiding overlapping between transmitted and diffracted components, particularly with those barriers having a “resonating” structure (cavities, etc.); they often cause a transmitted impulse response “ringing” for several milliseconds (even 20-30 ms), which means that a complete separation of the diffracted components would require a minimum height of 7 or more meters.

Again, when this overlapping problem occurs, the standard does not provide clear indications about the real minimum height of the barrier (as the length of the transmitted component is always assumed to be shorter than the standard Adrienne Window, which only accommodates a length of approximately 5.0 ms). Furthermore, the standard does not define how to proceed when the operator is asked to qualify a noise barrier of limited height, as it often occurs in practice, as shown in Figure 9. This gap in the standard can create wrong classifications, which, with reference to the Sound Insulation Index, can either result in significant underestimation or overestimation of the real values.



Figure 9. Barrier that doesn't meet minimum dimension requirements.

Scattering surfaces

For RI index measurements, the computation formula (1) inherently assumes that the reflection is specular, and that the reflected sound appears to be originated from a sound source located in the “mirror image” position.

Of consequence, the amplitude of the reflected sound is “boosted” by multiplying it for the running time t , which is perfectly correct for a specular reflection, as the sound diverges over a sphere which radius is equal to the path travelled, and hence is proportional to the time required for travelling such distance.

But, when the surface of the barrier is very rough, it behaves as a scattering surface. This means that every point of the barrier becomes a secondary source of uncorrelated noise, radiating a sound wave which attenuates following a much more complex law.

For comparing the behaviour of a specular surface with a completely-scattering surface, a simulation with the computer program Ramsete [6,7] has been performed.

Figure 10 shows the geometry of the test case: it is a barrier having an height of 6m, a length of 18 m, without posts, and thus not encountering any of the geometrical problems outlined in the previous paragraphs.

The sound source and the microphone are located in the standard positions for the normal-incidence test ($\alpha = 90^\circ$).

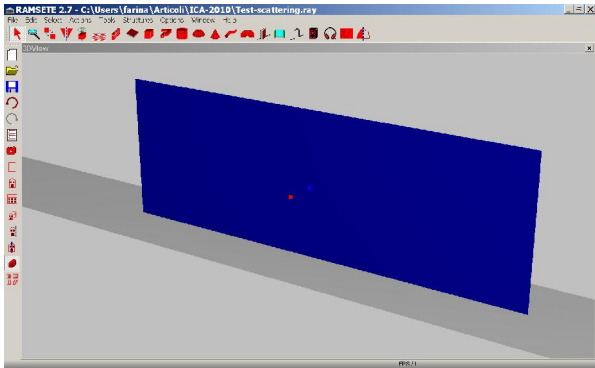

Figure 10. Geometry for the scattering test case

Figure 11 shows the computed impulse responses for the case of a completely reflecting surface (RI=1 at every frequency), and considering the surface perfectly specular (scattering coefficient $s=0$) and perfectly diffusive (scattering coefficient $s=1$).

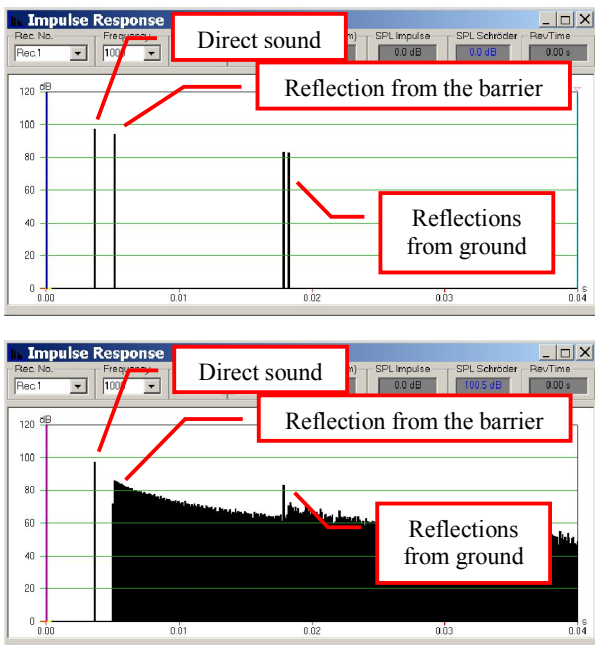

Figure 11. Impulse Responses computed by Ramsete

Applying eq. (1) at the results of these two simulations, the following values of RI are found:

Table 3.

Reflection Index 100% specular Barrier	1.000
Reflection Index 100% scattering Barrier	3.067

In the case of the scattering barrier, the result is clearly wrong. Multiplying by t the amplitude of randomly-scattered sound over-corrects the late arrivals.

If one could integrate all the reflected energy for an infinite time, in front of an infinite scattering surface, one would find that the total reflected energy is exactly equal to the incident energy, as the surface is not absorbing any energy, so the total energy flux going towards the surface should come back, early or late...

However, due to the limited length of the Adrienne window, only the energy reflected by a portion of the scattering surface is being integrated. Let's call K the factor, lesser than 1, expressing the ratio between the energy reflected by this portion of the surface and the total reflected energy (which is equal to the total incident energy, as our surface has no absorption).

Considering that the Adrienne window limits the energy integration to a time interval approximately long 5.4 ms after the beginning of the reflected energy, in the case of the normal incidence measurement the value of the factor K is equal, approximately, to 0.93262.

The value of the reflection index RI could be computed making the ratio between the energy reflected by the measured surface and the energy which would be reflected by an ideal surface having a reflection index =1.

$$RI_j = \frac{\int_{\Delta f_j} |F[h_r(t) \cdot w_r(t)]|^2 \cdot df}{K \cdot \int_{\Delta f_j} |F[h_i(t) \cdot w_i(t)]|^2 \cdot df} \quad (8)$$

Applying the above formula (8) to the results of the numerical simulation visible in Figure 11, an almost correct value for RI is found:

$$RI_{scattering} = 0.99958$$

Of course, in case of measurements at 9 incidence angles, 9 different values for the factor K should be used. Thus, the complete formula for computing RI of a scattering surface is:

$$RI_j = \frac{1}{n_j} \cdot \sum_{k=1}^{n_j} \frac{\int_{\Delta f_j} |F[h_{r,k}(t) \cdot w_r(t)]|^2 \cdot df}{K_k \cdot \int_{\Delta f_j} |F[h_i(t) \cdot w_i(t)]|^2 \cdot df} \quad (9)$$

This means that the usage of eq. 1 yields completely wrong results for a 100% scattering surface, and instead eq. (9) should be used.

However, a typical rough noise barrier will not be 100% scattering, nor 100% specular: at different frequencies, the barrier will exhibit a variable scattering coefficient, ranging between 0 and 100%. And, as the value of the scattering coefficient is not known, it is impossible to establish what percentage of the reflected energy is specular, and what percentage is scattered.

We conclude therefore that the whole procedure cannot work for measuring RI of a partially-scattering rough surface.

RESULTS OF SOME IN SITU TESTS

Here the results of some CEN/TS 1793-5 measurements will be shown. The first two barriers under test are installed in "Grande Viabilità Triestina" between Cattinara and Patriciano (Italy).

Barrier A is made by metallic panels, it has an height of 5 meters and a thickness of 0.20 meters.

Barrier B is made by wood; it is 2 meters tall and 0.12 meter thick.

The results of the measurements by the CEN/TS 1793-5 method are presented in Table 4.

Table 4. Measurement results

	Barrier A	Barrier B
DL_{RI}	4.52 [dB]	3.41 [dB]
DL_{SI} (element)	25.6 [dB]	18.5 [dB]
DL_{SI} (post)	23.1 [dB]	19.3 [dB]

Comparison of the behaviour of the two barriers is shown in the following figures in 1/3 octave bands:

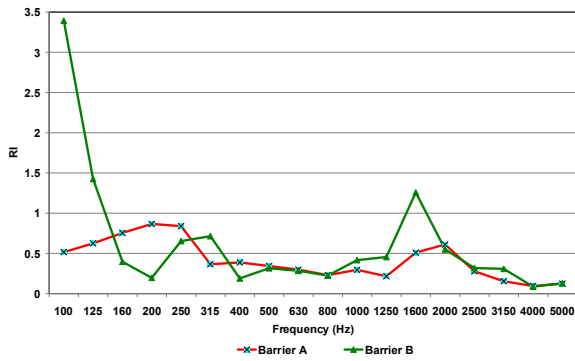

Figure 12. RI comparison

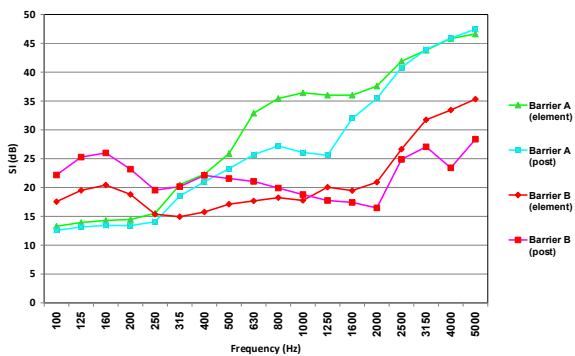

Figure 13. SI comparison

Comparison between laboratory and CEN/TS 1793-5 measurements – Sound insulation

Table 5 compares the single-rating numbers DL_R and DL_{SI} . DL_R represents the result in laboratory, the “in situ” behaviour is represented by DL_{SI} . The fact that the two coefficients can deviate is known, proved by other tests and documented [8].

In barrier “A” this difference can be safely considered null: a gap of 0.4 dB is physically insignificant. Barrier “B” manifests instead a too wide gap between values. As described before, this effect is due to the short delay between transmitted and diffracted components: Figure 14 shows how the diffracted component falls inside the Adrienne window, because of the limited height of barrier “B”, compromising the whole result.

Table 5. Sound insulation results comparison

	DL_R	DL_{SI}
Barrier “A”	26 [dB]	25.6 [dB]
Barrier “B”	29 [dB]	18.5 [dB]

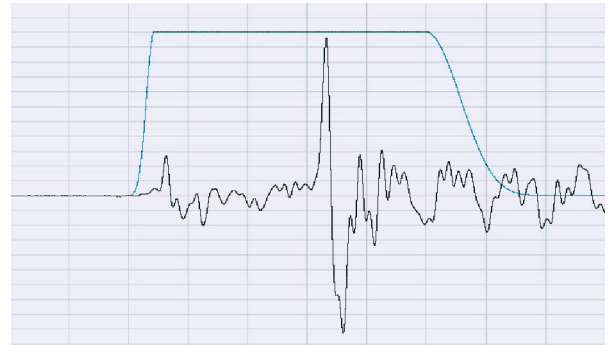

Figure 14. Barrier “B”: transmitted and diffracted components both fall inside the Adrienne window.

Comparison between laboratory and CEN/TS 1793-5 measurements – Reflection index

Table 6 shows the comparison between laboratory and “in situ” measurement results. DL_a represents the laboratory single number rating of sound absorption, DL_{RI} the “in situ” value according to CEN/TS 1793-5.

A ratio of approximately 4 can be found between DL_a and DL_{RI} . In perfect compliance with the results reported in [9], the “in situ” values result to strongly underestimate the real effectiveness of the barrier. This fact is perfectly in line with the problems exposed with regard to scattering surfaces and ground reflection.

Table 6. Single-rating numbers comparison (reflection)

	DL_a	DL_{RI}
Barrier “A”	20 [dB]	4.52 [dB]
Barrier “B”	12 [dB]	3.41 [dB]

AN ALTERNATIVE APPROACH: SOUND INTENSITY MEASUREMENTS

It has been shown how results obtained using CEN/TS 1793-5 for sound reflection tend to underestimate the barrier performance: in general, lab results are not comparable with “in situ” results and the final classification of the device can be very different.

An alternative measurement method, making use of Sound Intensity, has been attempted, based on the theoretical formulation presented in [10].

This method has been applied to the measurement of the absorptive/reflective properties of a third type of barrier,

made of concrete and expanded clay, which is shown in the following Figure 15.

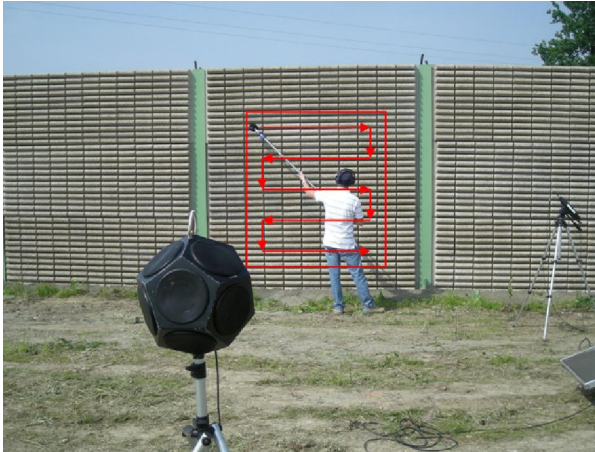

Figure 15. Sound Intensity measurement (manual sweep) of barrier “C”

Two “scanning” measurements are performed moving the Sound Intensity probe very close to the barrier surface, and keeping a minimum distance from ground, barrier’s top edge and posts. The loudspeaker radiates pink noise, and the averaging lasts for a couple of minutes, so the measurement is very fast.

The Sound Intensity analyser measures three physical quantities: Active Intensity (AI), Sound Pressure (SP), and Particle Velocity (PV). From the latter two, a derived quantity, the Energy Density (ED) is found:

$$ED = \frac{I}{2} \cdot \left[\rho \cdot PV^2 + \frac{SP^2}{\rho \cdot c^2} \right] \quad (10)$$

The reflection coefficient r and the absorption coefficient α can finally be obtained by the ratio of AI and ED:

$$r = \frac{I - \frac{AI}{ED \cdot c}}{I + \frac{AI}{ED \cdot c}} \quad \alpha = 1 - r \quad (11)$$

Figure 16 shows the comparison between the absorption coefficients α measured “in situ” by means of the sound intensity method, with the value measured in the laboratory according to ISO 354, and with the value computed back from the reflection index obtained by employing the CEN/TS 1793/5 method ($\alpha=1-RI$).

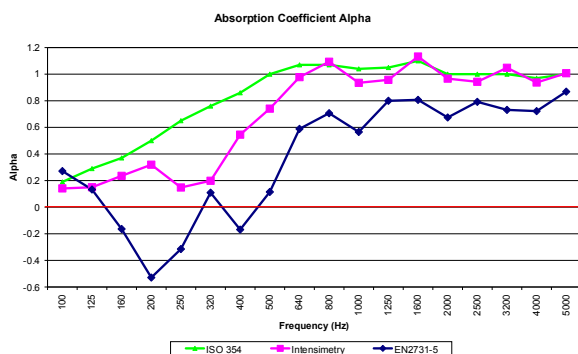

Figure 16. Sound Intensity measurement results (barrier “C”) vs. ISO 354 and CEN/TS 1793/5

It can be seen how, at low-medium frequencies, the CEN/TS 1793/5 method provides completely wrong results, with values of Reflection Index greater than 1, and hence “negative” values of α .

Table 7 shows the single-number rating of this barrier based on the three measurement methods:

Table 7. Single-rating numbers comparison (reflection)

	DL_a <i>Laboratory</i>	DL_{RI} <i>Intensimetry</i>	DL_{RI} <i>CEN/TS 1793/5</i>
Barrier “C”	15.5 [dB]	8.6 [dB]	3.3 [dB]

Using the new Sound Intensity method, the measured data are more closely comparable with the laboratory test and therefore the final classification of the barrier will be in line with the manufacturer’s declaration, proving compliance of the tested sample with the minimum limits required.

The whole measurement procedure lasts less than 20 minutes, thus ensuring to get good time invariance of the system, and to be able to repeat the assessment of many samples in a single work day.

CONCLUSIONS

The use on CEN/TS 1793-5 to classify the effectiveness of barrier has been shown to provide results that agree with the laboratory only in sound insulation test and only when the barrier is very tall and without resonant cavities: for example, the deviation between laboratory and “in situ” results for barrier “A” is negligible. When these geometrical and structural requirements are not met, the result deviates significantly (as it happened for barrier “B”).

In this case, it has been shown how DL_{SI} can be strongly affected by the diffracted component of the impulse response, if it falls within the Adrienne window. Depending on how the operator deals with this problem, the final result of the Sound Insulation rating can either be underestimated or overestimated.

Reflection index results obtained by “in situ” method did show systematic underestimation of the effectiveness of the devices. The final single-rating number obtained for both barriers “A” and “B” is approximately 4 times lower than the laboratory value. It has been noticed how scattering surfaces effects and ground reflections could falsify the result. The scattering problem has been addressed and a new formula (9) has been proposed instead of (1). However it has been noticed how this new approach could not be used for “real world” barriers because of the lack of knowledge of the frequency dependent scattering coefficient: thus, this systematic error cannot be avoided.

In practice, the CEN-TS 1793/5 method revealed to be completely unusable for measuring reflection index; of consequence, an approach based on sound intensity measurements has been proposed for estimating correctly the sound reflection from the barrier, also for devices of limited height and with very rough surface. It has been shown how, employing this alternative measurement method, it is possible to estimate correctly the sound absorbing performance of the barrier, while minimizing the time required for the test, therefore minimizing the time variance of the system.

REFERENCES

- [1] A. Farina – “Simultaneous measurement of impulse response and distortion with a swept-sine technique”, 110th AES Convention, February 2000.
- [2] S. Müller, P. Massarani – “Transfer-Function Measurement with Sweeps”, JAES Vol. 49 Issue 6, pp. 443-471; June 2001.
- [3] G. Stan, J.J. Embrechts, D. Archambeau – “Comparison of Different Impulse Response Measurement Techniques”, JAES Vol. 50, Issue 4, p. 249; April 2002.
- [4] J. Vanderkooy, “Aspects of MLS measuring systems”, JAES Vol. 42, Issue 4, pp. 219-231; April 1994.
- [5] Peter Svensson, Johan L. Nielsen, “Errors in MLS Measurements Caused by Time Variance in Acoustic Systems”, JAES Vol. 47 Issue 11, pp. 907-927; November 1999.
- [6] A. Farina - "RAMSETE - a new Pyramid Tracer for medium and large scale acoustic problems" - Euro-Noise 95 Conference, Lyon 21-23 march 1995.
- [7] A. Farina, “A new method for measuring the scattering coefficient and the diffusion coefficient of panels”, *Acustica/Acta Acustica*, vol. 86, n. 6 pp. 928-942, December 2000
- [8] M. Garai, P. Guidorzi, “European methodology for testing the airborne sound insulation characteristics of noise barriers in situ: Experimental verification and comparison with laboratory data”, *J. Acoust. Soc. Am.*, Vol. 108, No. 3, Pt. 1, Sep 2000
- [9] M. Garai, P. Guidorzi, “Experimental verification of the European methodology for testing noise barriers in situ: sound reflection”, *Proc. Inter-Noise 2000*, Nice, France, 477-482 (2000).
- [10] A. Farina, A. Torelli, “Measurement of the sound absorption coefficient of materials with a new sound intensity technique”, Pre-prints of the 102nd AES Conference, Berlin, 23-26 March 1997